



angle design
DN 25

VACUUM REDUCER LPR[®]T

Application

The self-contained stainless steel regulators act as negative pressure reducing and back pressure regulating valves, controlling vacuums in the mbar range. They are used with inert gases such as nitrogen for tanks, reactors, centrifuges and agitating tubs.

The regulators are designed to meet requirements in the chemical, pharmaceutical and biotechnology industries and are particularly corrosion resistant and reliable.

Design

The large proportioned, spring-loaded diaphragm actuator with directly-controlled valve seat ensures precise control with low hysteresis. The regulators function without auxiliary power supply. High overpressure strength and safe regulator function is achieved by means of the supported diaphragm with long spindle guide. The regulator has a low degree of clearance volume and is self-draining.

Description

The components coming in contact with the product are manufactured from CrNiMo steel 1.4435 / 1.4404. The diaphragm and seals are made of PTFE and the regulator seat is made of perfluoroelastomer (FFKM – Isolast®, Chemraz®, Kalrez®) as standard, or fluoroelastomer (FKM: Viton®). These materials guarantee high corrosion resistance and excellent sealing, even at zero flow. The design has a low degree of clearance volume and is self-draining (suitable for CIP). On request, we can supply regulators in Hastelloy, Tantal or plastic etc. with the appropriate certification.

The surface finish for the stainless-steel version is better than Ra 1.6 for housing parts in contact with the medium, better than Ra 0.8 for internal functional parts and better than Ra 3.2 for the outer housing.

Technical data

Nominal diameter:	DN 25 / 1"
Regulating range P2:	N.. to 800 mbar (200 mbar abs.)
	D (pressure difference) to 4 bar = P3
Inlet pressure P1:	max. 10 bar
Vakuum proof	
Pressure connections:	Flange / thread (Special version available on request)
Weight:	5,0 kg to 8,3 kg
Temperature:	-20 ° to +120 °C for EPDM (Dependent on pressure conditions) -20 ° to +130 °C for FKM -20 ° to +160 °C for PTFE
Testing and inspection:	According to IEC 60534-4
Pressure tightness:	Sealing category V

Section drawing for Hastelloy model and regulating pressure range "M" available on request.

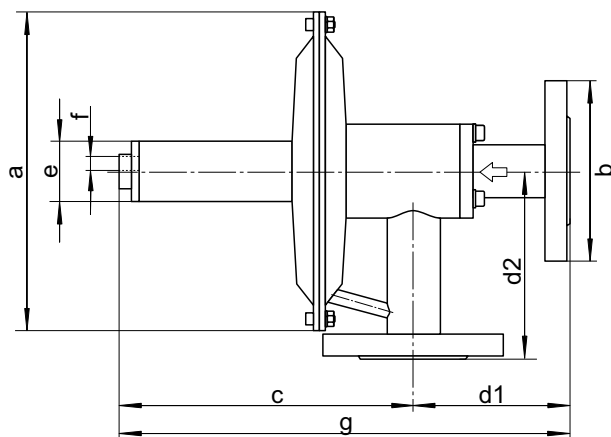
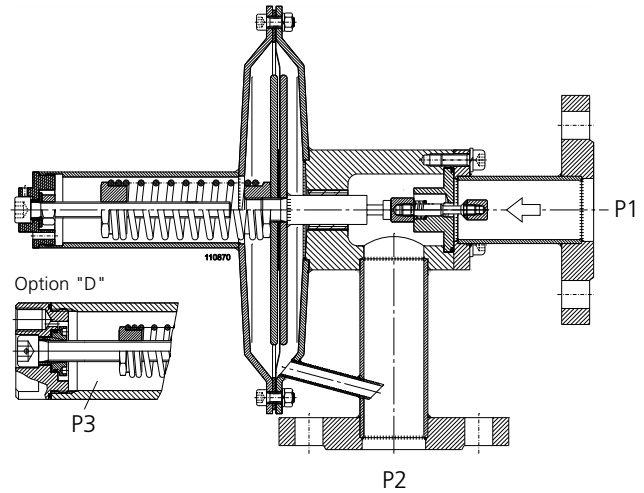
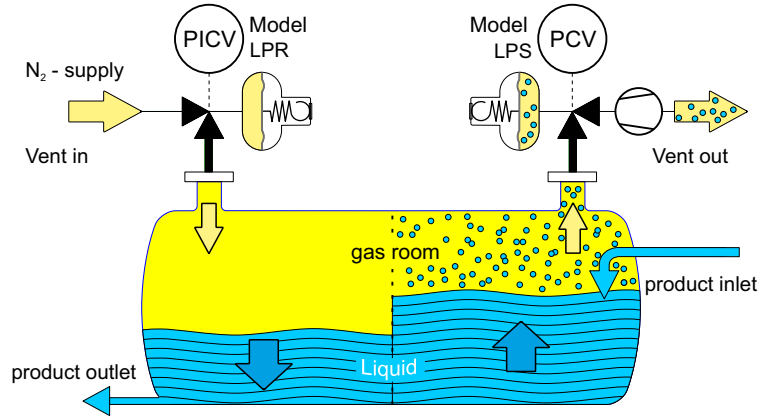

Model dimensions	pressure connection	a	b	c	g	d1 x d2	e	f Option "D"
LPR-T-025...-N...-...-	DIN DN25 PN16 ANSI 1" 150 lbs BSP 1" female thread NPTF 1" female thread	Ø 204	Ø115 (DIN)	190	290	Standard 100 x 120 If desired 100 x 100	Ø38 (M36)	G 1/4" female thread (dimen- sion "e" is always Ø54 (M48) with Option "D"
			Ø108 (ANSI)	208	308		Ø54 (M48)	



angle design
DN 25

MODEL CODE LPR[®]T

1			2			3			4			5			6			7		
Design			Nominal diameter DN/ pressure connection			Flow capacity			Regulating pressure range			Material			Options			Specials		
LP	R	T	-	025	.	-	..	-	N..	-	...	-	.	-	.	-	Xn			

2 Nominal diameter DN/ Pressure connection

D	Flange:	DIN EN 1092-1, B1 DN 25 PN 16
A	Flange:	ANSI B 16.5, 1" 150 lbs
B	Thread:	1" BSP female thread
N	Thread:	1" NPTF female thread

3 Flow capacity

07	Seat	ø7 mm	kv = 0.70
12	Seat	on request	
16	Seat	on request	

4 Regulating pressure range P2 (mbar)

N01	+5 to -10	N10	-16 to -100
N02	-5 to -20	N20	-30 to -200
N05	-8 to -50	N50	-80 to -500

5 Material (only the same colours can be combined)

Housing/ internal components	Seat seal	Diaphragm/ Regulating range
S 1.4435 (1.4404)/ 1.4435 (1.4404)	K FFKM	P PTFE/ N..
G 1.4435 (1.4404)/ HC 22 (2.4602)	V FKM	E EPDM/ N..
H HC 22 (2.4602)/ HC 22 (2.4602)	E EPDM	G PTFE-glass fibre reinforced / L..
	C FFKM con- forms to FDA	V FKM/ N..

Example: Housing/internal components with material code "G" or "H" (red) are only combined with seat of type "K" or "C" and with diaphragm type "P" or "G".

Housing/internal components with material code "S" can be combined with all seat and diaphragm materials (yellow).

6 Options

D	Differential pressure connection
E*	External impulse connection (standard 5/8" -20 UNS)
G	Pressure gauge connection G¼

*The welded nipple is provided for connecting a pipe with ø 10. Included are a Swagelok nut and a front and rear clamping ring. (Specials on request).

7 Specials

X0	If you require, for example, ATEX, PED, special connections, external control, rain hood, a fixed setting for P2 ..., please enter an X in this field with the number of desired Specials. Each of the specials must be described in writing.
X1	
X2	
Xn	For special versions and certifications, please contact the manufacturer or the appropriate sales representative.

Flow table [flow quantities in Nm³/h]

P1 [bar rel.]	0.15	0.25	0.40	0.65	1.0	1.5	2.5	4.0	6.0	10	Seat size
-10	13.4	16.8	20.4	27.1	33.6	42.0	58.8	84	118	185	ø7 mm
-20	12.7	17.0	21.7	26.9	33.6	42.0	58.8	84	118	185	ø7 mm
-100	15.9	18.9	22.5	27.6	33.6	42.0	58.8	84	118	185	ø7 mm

It is recommended to design for operation at a maximum of 70% of the flow values.
P1 = supply pressure P2 = regulating pressure

Dependency on inlet pressure (per -1 bar / +1 bar change in P1)

Seat ø7 mm	- 3 mbar / + 3 mbar	Seat ø16 mm	- 13 mbar / + 13 mbar
Seat ø12 mm	- 8 mbar / + 8 mbar		

Pressure / flow characteristic

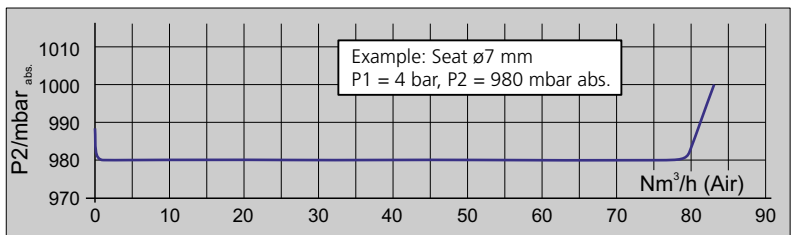

Installation

The preferred installation position is with vertical diaphragm housing and horizontal input. Pressure fixed unit is adjusted in this position. The output pressure increases by approximately 4 mbar for installation with horizontal diaphragm housing. The installation position must be specified.

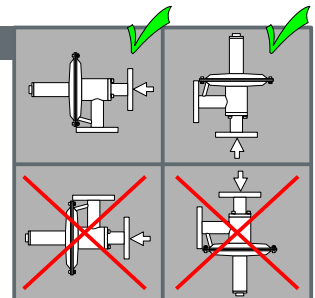

Mounting and start up

- Before connecting the pressure regulator please make sure
 - 1.1 to compare the plant data with the name plate
 - 1.2 the values marked on the name plate are the values measured during our functional inspection
 - 1.3 to check the corrosion resistance of the material
 - 1.4 to blow out impurities in the pipes
 - 1.5 to note the flow direction – it is marked with an arrow on the housing
 - 1.6 to open inlet pipes slowly
- LPRT adjust reduced pressure: (Relative pressure)
 - 2.1 Set a light flow (1Nm³ /h). Set the pressure +/- as required using a hexagonal wrench.
 - 2.2 The setting can be secured with a seal.
 - 3 Adjust the LPRT differential pressure (-D) with the servo-regulator
 - 3.1 If the D-connection is pressurised with the servo-pressure, the working pressure is added by the servo-pressure.
 - 4 LPRT-N Set negative pressure
 - 4.1 set a light flow (1Nm³ /h). Set the pressure +/- as required using a hexagonal wrench
 - 4.2 The setting can be secured with a seal.